

# WT2000B02



WT2000B02 is MP3 record module, with folder classify, specified file name play and specified index sequence play. According file name to record in specified file or according index sequence to record and play, and specified delete any file in the specified folder.

2. Features:

1. Support WAV, WMA, MP3 format
2. Support 48KHz sample rate, 32-128Kbps bit rate MP3 record format
3. Inner micro SD card or U disk as storage, maximum support 32G micro SD card or 32G U disk
4. With three record method, microphone, line-record and dural track record
5. Support with 22 byte file name record mode
6. Record duration time about 3 months
7. Adopt FAT and FAT 32 file system
8. Through USB interface to renewal inner micro SD card audio
9. Support USB sound card function
10. Use UART serial port communication
11. Inner 1W amplifier, direct drive 8ohm/1W speaker, with 32 selective volumes
12. Power supply: DC 5V

Note: the module without key operation mode, match use with MCU.

**3. Technology Specification**

Name	Function
Audio Format	Support 8K-44.1K sample rate, 8-224Kbps bit rate Support 8K-44.1K sample rate WAV audio file Support 8K-44.1K sample rate WMA audio file
Store Volume	Max support 32GB TF card Max support 32GB U disk
USB Interface	Full speed 2.0
Power Supply	DC3.3~5V
Rated Current	20~250mA (related with load)
IO Port Level	3.3V TTL Level
Size	21.mm*18mm*4mm
Working Temperature	-40~85 degree
Humidity	5%~95%

4. Pin Image

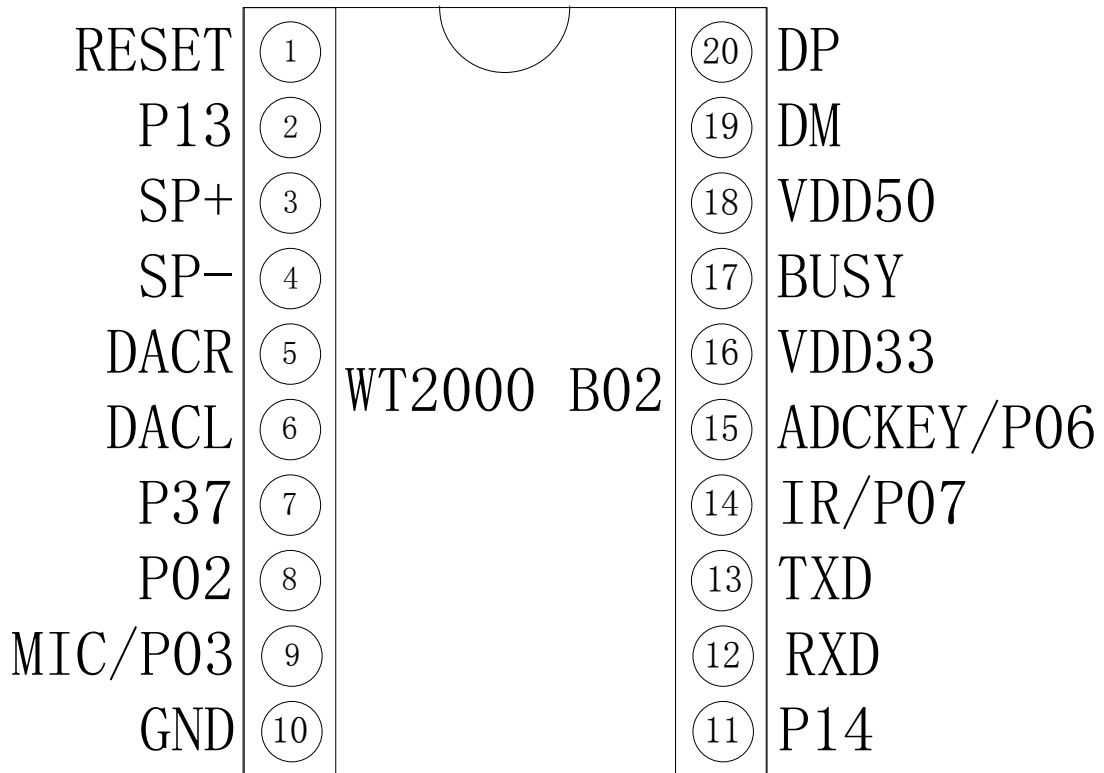

Pin Image	Pin Name	Type	Function Description
1	RESET/P35	I	IO port (unused)
2	P13	IO	IO port
3	SP+	AO	Speaker terminal
4	SP-	AO	Speaker terminal
5	DACR	IO	DAC right channel output
6	DACL	IO	DAC left channel output
7	AUX_L	IO	AUX recording audio signal left channel input end
8	AUX_R	IO	AUX recording audio signal right channel input end
9	MIC/LINE IN	AI	Microphone terminal/circuit recording input end
10	GND	PWP	Power Ground
11	P14	I/O	IO port (unused)
12	TXD	O	UART data output end
13	RXD	I	UART data input end
14	P07	I/O	I/O port (unused)
15	ADC_KEY	I	ADC key connecting pin (unused)
16	VCC33	PWP	LDO 3.3V power output end
17	BUSY	I/O	Busy signal
18	VDD	PWP	Module power end
19	DM	IO	USB data end DM
20	DP	IO	USB data end DP

Note:

Power output port VDD33 not allow supply power to external device, only for low power consumption like pull-up resistor.

### 5. Serial Communication Control Command

Support **UART Communication**: baud rate: 9600 bps, start bit: 0, stop bit: 1, format: start bit (1bit)+data bit(8 bit)+stop bit (1 bit). Data transmission is 8 byte, low digit first.

CMD Detail Annotate	Function	Input Parameter
A2	Specified file index play command	File Index
A3	Specified file name play	File Name
A4	File index play command in the specified folder	Folder name, file index
A5	Music file name play command in specified folder	Folder name, file name
AA	Play/pause command	N/C
AB	Stop command	N/C
AC	Next command	N/C
AD	Last command	N/C
AE	Volume control command	Volume level
AF	Specified play mode	Option mode
D0	Fast forward command	N/C
D1	Fast backward command	N/C
D2	External storage chooses command code	U disk or SD card
D3	Specified audio input channel and gain	Channel mode
D4	Setting record quality command	Code rate option
D5	Specified file index record command	File index
D6	Specified file name record command	File name
D7	Index record command in specified folder	Folder, index
D8	File name record command in specified folder	File name, folder
D9	Stop record command	N/C

DA	Delete specified index command	Index
DB	Delete specified file name command	File name
DC	Delete index command in specified folder	Folder, index
DD	Delete corresponding file command of file name in specified folder	Folder, file name
DE	Delete all commands	N/C

### 5.1 Control Protocol

WT2000 inner standard UART ASYNC serial interface, belong to 3.3V TTL level interface.

Through MAX 3232 chip convert into RS232 level.

Communication data format is start bit: 1 bit, Data bit: 8 bit, parity bit: none, stop bit: 1 bit. Use computer serial debug assistance to set correct serial parameter, like below image:



### Protocol Command Format:

Start Bit	Length	Operation Code	Parameter	Check Code	End Code
0X7E	See below	See below	See below	See below	0XEF

**Note:** all data are hexadecimal number. "length" means length + operation code + check code, "check code" means length + operation code + parameter value (check code use one byte, less than 8 digit, over will be cut down). See below specified file index play command, length is 5 byte.

### 5.2. Play Classify Operation Command

#### 5.2.1. Operational Order Return Code Format

**Note:** execute all above commands, code.

<b>Operate Code</b>
XX

return corresponding byte of operation

### 5.2.2. Specified File Index Play Command

This command can specify corresponding index audio play in storage, influenced by file stored order.

File sequence according to index sequence.

Start bit	Length	Command	Audio high order	Audio low order	Check order	End code
7E	05	A2	00	01	A8	EF

**Note:** specified play, if specified audio not exist, will be stop.

Return code: 00 means OK, start playing

01 means EMP have this file

### 5.2.3. Specified File Name Play

This command is allow to play in root directory of specified storage, if file name less than or equal to 8bit, send code as below:

Start bit	Length	Command	File Name (High-Low)			Check Code	End Code	
7E	07	A3	54('T')	30('0')	30('0')	32('2')	90	EF

54,30,30,32 is T002 ASCLL code, only support file name as ASCLL code. Above command stand for specified root directory file name as "T002XXX.MP3" to play, only forward four digit should be correspondence.

If file name over 8bit, for instance, file name is T0000000000002, it will send as below:

Start Code	Length	Command	File Name (High-Low)							Check Code	End Code	
7E	11	A3	54 ( 'T' )	30 ( '0' )	30 ( '0' )	30 ( '0' )	30 ( '0' )	30 ( '0' )	7E	31	A7	EF

That's mean it will only get the front six digit and 7E31 as file name.

Return code: →: 00 means OK, start playing

→: 01 means EMP have no the file

### 5.2.4. File Index Play Command in Specified Folder

(folder name with five byte)

Search folder audio start from root directory, root directory file allow place in it.

Start Code	Length	Command	Folder Name (High-Low)					File Index (High-Low)		Check Code	End Code
7E	0A	A4	'M' (4D)	'U' (55)	'S' (53)	'I' (49)	'C' (43)	00	01	30	EF

Folder Name exist in the form of ASCLL code, above command means play the first song audio file (0001), folder name as "MUSIC" in specified root directory

Return code →: 00 means OK, start playing

→: 01 means EMP without the file

### 5.2.5. Music File Name Play Command in Specified Folder

This command is allow play in specified root directory (folder name with five byte, file name length unlimit)

If file name less than or equal to 8byte, send code as below

Start Code	Length	Command	Folder Name (high-low)					File Index (high-low)				Check Code	End Code
7E	0C	A5	'M' (4D)	'U' (55)	'S' (53)	'I' (49)	'C' (43)	54 'T'	30 '0'	30 '0'	3 '2' '2'	18	EF

The ASCLL code of 54, 30, 30 and 32 are T002, the folder name and file name be formed as ASCLL. Above command means file name formed as "T002XXX.MP3" and folder name as "MUSIC" in specified folder

The front four digit must correspondence

Return code: →:00 means OK start playing

→: 01 means EMP have no the file

If file name over 8bit, for instance, file name is T0000000000002, it will send as below:

Start Code	Length	Command	Folder Name (High-Low)				
7E	10	A5	'M' (4D)	'U' (55)	'S' (53)	'I' (49)	'C' (43)

Folder Name (High-Low)								Check Code	End Code
54 ( 'T' )	30 ( '0' )	30 ( '0' )	30 ( '0' )	30 ( '0' )	30 ( '0' )	7E	31	29	EF

That's mean it will only get the front six digit and 7E31 as file name.

Return code: →: 00 means OK, start playing

→: 01 means EMP have no the file

### 5.2.6. Pause/Play Command

Start Code	Length	Command	Check Code	End Code
7E	03	AA	AD	EF

First time send this command, it will pause play music, after send data again, it continue to play from pause point

Response →00 means OK, execute command successful

→01 means FALT, command fault

### 5.2.7. Stop Playing Command

Start Code	Length	Command	Check Code	End Code
7E	03	AB	AE	EF

Send this command, stop to play current playing music

Response: →00, means OK, execute command successful

→01, means FAIL, command fault

### 5.2.8. Next Command

Start Code	Length	Command	Check Code	End Code
7E	03	AC	AF	EF

This command can trigger next music, when play last music, send the command to trigger play first music.

Response: →00, means OK execute command successful

→01, means FAIL, command fault

### 5.2.9. Previous Command

Start Code	Length	Command	Check Code	End Code
7E	03	AD	B0	EF

The command can trigger play previous music, when play first music, send the command can trigger play the last music.

Response: →00, means OK, execute command successful

→01, means FAIL, command fault

### 5.2.10. Volume Control Command

There are 32 level volumes in total, from 00 to 31, 00 as mute and the 31 level volumes is the biggest volume. (30 volume in default)

Start Code	Length	Command	Volume Level	Check Code	End Code
7E	04	AE	1F	D1	EF

Example is the biggest volume level 30, the command realizes modify adjust volume, with memory power down when EEPROM exist.

Response: →00, means OK execute command successful, playable volume set as specified value

→01, means FAIL, command fault

### 5.2.11. Specified Play Mode

Start Code	Length	Command	Parameter	Check Code	End Code
7E	04	AF	00: single non cycle play mode (default)	B3	EF
			01: single cycle play	B4	
			02: all the song cycle play	B5	
			03: random mode	B6	
			04: folder cycle play	B7	



**Note:** after amend mode will be stored, but every power on or restart will recover to default status.

Response: →00, means OK, execute command successful

→01, means FAIL, command fault

### 5.2.12. Fast Forward Command

Start Code	Length	Command	Check Code	End Code
7E	03	D0	D3	EF

Send this command, first time to start fast forward, second time over fast forward and continue to play audio. If not play, it will play first.

Response: →00, means OK, execute command successful

→01, means FAIL, command fault

### 5.2.13. Fast Backward Command

Start Code	Length	Command	Check Code	End Code
7E	03	D1	D4	EF

Send this command, first time to start fast backward, second time over fast forward and continue to play audio. If not play, it will play first.

Response: →00, means OK, execute command successful

→01, means FAIL, command fault

### 5.2.14. External Storage Operation Option Command

Meanwhile, WT2000B02 external plug-in U disk or use inner storage, one of them must be selected when operate. Inner SPI FLASH as specified operation in default. If have any special, U disk can be selected. When only have one plug in storage, execute the storage is available. (after change mode, it is best to check current work drive)

Start Code	Length	Command	Parameter	Check Code	End Code
7E	04	D2	00: the drive change into SD card (default)	D6	EF
			01: the drive change into U disk	D7	

Return Code: →:00, means OK, command execution

→: 01 means haven't executed or have no storage

## 5.3. Recording Operation Command

5.3.1. Specified audio input channel and gain, suitable for any external signals.

Audio input channel can choose MIC or AUX, meanwhile, setting inner gain value.

Start Code	Length	Command	Parameter	Check Code	End Code
7E	04	D3	00 : MIC signal input gain 10DB (default)	D7	EF

			01: external LINE-IN signal gain 3DB	D8	
			02: external dual track AUX (AUX_L and AUX_R) signal gain 3DB	D9	

**Note:**

1. Every signal input port and gain refer to below corresponding circuit to use.
2. Dural track AUX recording with stereo

Return: : →: 00 means OK, execute command

→: 01 means haven't executed

**5.3.2. Setting Recording Quality Command**

WT2000 with different record MP3 code rate.

Start Code	Length	Command	Parameter	Check Code	End Code
7E	04	D4	00: 128KPBS (default)	D8	EF
			01: 96KPBS	D9	
			02: 64KPBS	DA	
			03:32KPBS	DB	

Return: : →: 00 means OK, execute command

→: 01 means haven't executed

**5.3.3. Specified File Index Record**

This command automatic produce record of file name and folder record (file name with five byte)

Start Code	Length	Command	File Index	Check Code	End Code
7E	05	D5	00 02	DC	EF

00,02 means record second audio, if record file quantity over two section before, the audio will be cover.

Return Code: →: 00 means OK, start to record

→: 01 means full storage

→: 02 means fault, unsuccessful

**Note:** specified according to index record, default record file name is REXXX.MP3, three digit number, max record index No. is 999

**5.3.4. Specified File Name Record Command**

The command specified produce record of corresponding file name in root directory of specified storage. (file name max 22 byte)

Start Code	Length	Command	File name	Check Code	End Code
7E	07	D6	54'T' 30('0') 30('0') 32('2')	C3	EF

54, 30, 30, 32 are ASCLL code of T002, file name exist in the form of ASCLL code. Above

command means produce file name with "T002.MP3" in specified root directory.

Return code: →: 00 means OK, start to record

→: 01 means full storage

→: 02 means fault, unsuccessful

Note: long file name match front six byte, if the front six byte is the same, it will regard as same file name and cover it, re-record.

### 5.3.5. Index Record Command of Specified Folder

This command specified file name of file to record in root directory (file folder is fixed five byte, file length max 8 byte).

Start Code	Length	Command	Folder name (high-low)					File Index (high-low)		Check Code	End Code
7E	0A	D7	'M' (4D)	'U' (55)	'S' (53)	'I' (49)	'C' (43)	00	02	64	EF

"02" means the second audio in folder. Folder name and file name exist in the form of ASCLL code, above command means folder name as "MUSIC" produce second record file in specified root directory, start to record. If have no the file, it will automatic produce folder.

Return code: →: 00 means OK, start to record

→: 01 means full storage

→: 02 means fault, unsuccessful

**Note:** according index to record, default record file name as REXXX.MP3, three digit, the max record index is 999.

### 5.3.6. File Name Record Command in Specified Folder

This command specified file name of file to record in root directory (file folder is fixed five byte, file length max 22 byte).

Start Code	Length	Command	Folder Name (high-low)					File Name (high-low)				Check Code	End Code
7E	0C	D8	'M' (4D)	'U' (55)	'S' (53)	'I' (49)	'C' (43)	54 'T'	30 '0'	30 '0'	3 2 '2'	4B	EF

54, 30, 30, 32 are ASCLL code of T002, folder name and file name exist in the form of ASCLL code. Above command means folder name as "MUSIC" produce second record file, named as "T002.MP3" in specified root directory, start to record. If have no the file, it will automatic produce folder.

Return code: →: 00 means OK, start to record command

→: 01 means full storage

→: 02 means fault, unsuccessful

Note: long file name match front six byte, if the front six byte is the same, it will regard as same

file name and cover it, re-record.

### 5.3.7. Stop Record Command

Start Code	Length	Command	Check Code	End Code
7E	03	D9	DC	EF

After receive command, stop recording and produce finished record file

Response: →00 means OK, stop recording and produce record file (file name specified as record command)

→01 means FAIL fault mistake or produce record file unsuccessful

### Delete Specified Index Command

This command delete corresponding index record in root directory

Start Code	Length	Command	File Index (high-low)	Check Code	End Code
7E	05	DA	00 02	E1	EF

“00,02” means index corresponding second file, above command means delete second file command in root directory.

Return Code: →: 00 means OK, delete successful

→: 01 means have no the file

### 5.3.9. Delete Specified File Name Command

This command allow delete record of corresponding file name in root directory.

Start Code	Length	Command	File name (high-low)			Check Code	End Code
7E	07	DB	54('T')	30('0')	30('0')	32('2')	C8 EF

“54, 30, 30 and 32” are ASCLL code of T002. File name exist in the form of ASCLL code.

Above command means delete “T002.MP3” file in root directory.

Return Code: : →: 00 means OK, delete successful

→: 01 means without the file

### 5.3.10. Delete Index File Command in Specified Folder

This command can delete corresponding index serial number in root directory (file folder fixed five byte)

Start Code	Length	Command	Folder Name (high-low)					File Index (high-low)	Check Code	End Code
7E	0A	DC	'M' (4D)	'U' (55)	'S' (53)	'I' (49)	'C' (43)	00 02	69	EF

Folder name exist in the form of ASCLL code, above command specified delete index serial number 0002 of MP3 file (second song) of folder name “MUSIC”

Return Code: →:00 means OK, delete successful

→: 01 means without the file

### 5.3.11. Delete file command of corresponding file name in specified folder

This command can delete file of corresponding file name in root catalogue (folder name fixed five byte, file name length max 8 byte)

Start Code	Length	Command	Folder Name (high-low)					File Name(high-low)				Check Code	End Code
			'M' (4D)	'U' (55)	'S' (53)	'I' (49)	'C' (43)	54 'T'	30 '0'	30 '0'	3 2 '2'		
7E	0C	DD										50	EF

"54, 30, 30, 32" are ASCLL code of T002, folder name and file name exist in the form of ASCLL code. Above command means file name "T002.MP3" record file of "MUSIC" folder in specified delete root directory.

Return Code: →: 00 means OK, delete successful

→: 01 means have no the file

### 5.3.12. Delete All Command

Start Code	Length	Command	Check Code	End Code
7E	03	DE	E1	EF

After receive command, delete all audio file in storage

Response: →00, means OK, delete successful

→01, means delete fault, haven't execute

## 5.4. Read Operation Command

### 5.4.1. Read Current Setting Volume

Start Code	Length	Command	Check Code	End Code
7E	03	C1	C4	EF

#### Return Format

Operation Code	Return Value
0XC1	Volume Value (00-1F)

### 5.4.2. Read Current Working Status

Start Code	Length	Command	Check Code	End Code
7E	03	C2	C5	EF

#### Return Forma

Operation Code	Return Value
0XC2	01: Play, 02 : Stop, 03: Pause, 04: Record 05: fast forward, fast backward

#### 5.4.3. Read Music File Amount in Storage

Start Code	Length	Command	Check Code	End Code
7E	03	C5	C8	EF

#### Return Format

Operation Code	Return Value
0XC5	File Amount (sixteen place value)

**Note:** suggest use A0 play command to renew cache file amount, it will better to read the newest amount.

#### 5.4.4. Read Music File Amount of Specified Folder in Storage

Start Code	Length	Command	Folder Name (high-low)				Check Code	End Code	
7E	08	C6	'M' (4D)	'U' (55)	'S' (53)	'I' (49)	'C' (43)	4F	EF

#### Return Format

Operation Code	Return Value
0XC6	File Amount (sixteen bit)

**Note:** suggest use A0 play command to renew cache file amount, it will better to read the newest amount.

#### 5.4.5. Read the Audio Number of Playing File

Start Code	Length	Command	Check Code	End Code
7E	03	C9	CC	EF

#### Return Format

Operation Code	Return Value
0XC9	XX

#### 5.4.6. Read SD Card and U disk Connection Status (CA)

Start Code	Length	Command	Check Code	End Code
7E	03	CA	CD	EF

#### Return Format

Operation Code	Return Value
0XCA	XX

When S U disk insert or pull out, WT2000 will return data automatically.

Return Value: 00 means U disk in, 01 means there are inner storage, U disk not exist, 02

means only with U disk, 03 means inner storage and U disk are not exist.

#### 5.4.7. Look up File Name Weather Exist in Root Directory

Start Code	Length	Command	File Name (high-low)				Check Code	End Code
7E	07	CB	54 'T'	30 ('0')	30 ('0')	32 ('2')	B8	EF

Return Code: →: 00 means OK, exist

→: 01 means without the file

**Note:** suggest use A0 play command to renew cache file amount, it will better to read the newest amount.

#### 5.4.8. Look up File Name Weather Exist in Folder Root Directory

Start Code	Length	Command	Folder Name (high-low)					File Name (high-low)				Check Code	End Code
7E	0C	CC	'M' (4D)	'U' (55)	'S' (53)	'I' (49)	'C' (43)	54 'T'	30 '0'	30 '0'	32 '2'	3F	EF

Return Code: →: 00 means OK, exist

→: 01 means have no the file

**Note:** suggest use A0 play command to renew cache file amount, it will better to read the newest amount.

#### 5.4.9. Read Balance Space in Storage

Start Code	Length	Command	Check Code	End Code
7E	03	CE	D1	EF

#### Return Format

Operation Code	Return Value
0XCE	XXXX Balance Volume (M)

**Note:** suggest use A0 play command to renew cache file amount, it will better to read the newest amount.

### 6. Announcements:

1. During record, if full storage, it will stop record automatically and return 01 00.
2. When delete audio file, do not outage or pull out storage, otherwise, damage file or storage data.
3. Every 5s will store recording file automatically, if power down within 5s, it cannot store the data.
4. It will take longer time when start record and over record command return code, related about read and write speed of storage, it's finish after waiting receive back code.
5. Time interval must larger than 100ms when send every command.

## Apply Circuit Diagram

### WT2000B02 Microphone and U disk Connection Apply Circuit

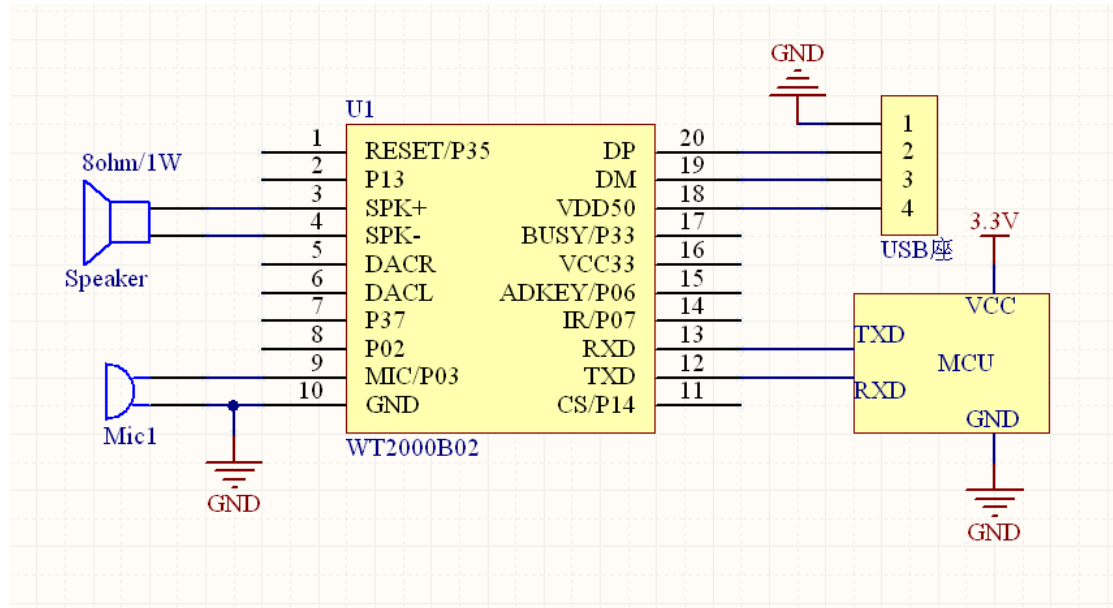

**Note:** WT2000B02 is 3.3 V IO system, direct connect with 3.3V MCU. Connect with 5V MCU need to increase level to convert circuit

### WT2000B02 LINE IN Recording Circuit

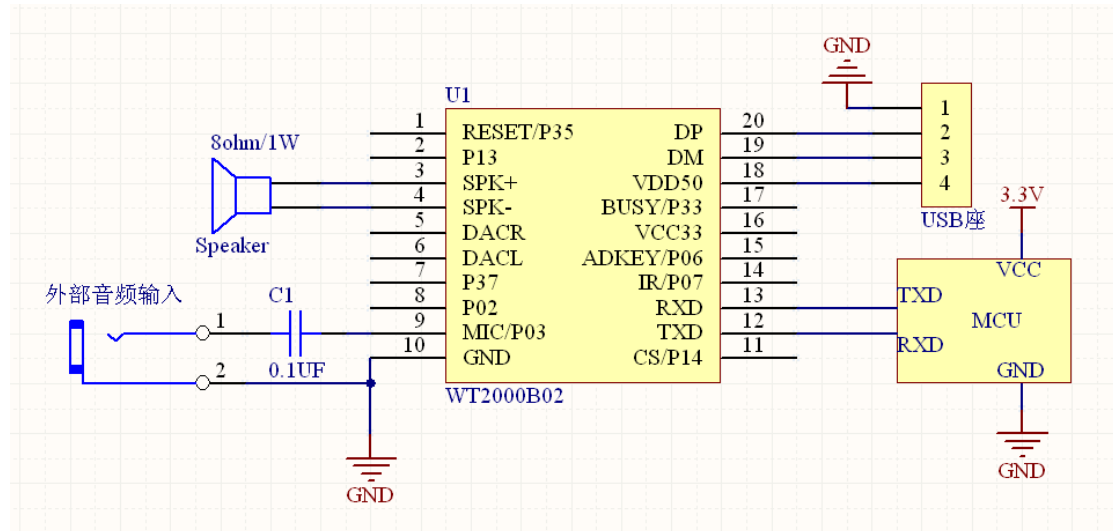

**Note:**

WT2000B02 is 3.3V IO system, direct connect with 3.3 V MCU. Connect with 5V MCU need to increase level to convert circuit

Single track record scene of external circuit input audio signal need use the apply circuit.

Suggest use external audio input signal within 2.8V.

Coupling capacity value is within 0.1Uf to 1uf.

### AUX Record Circuit



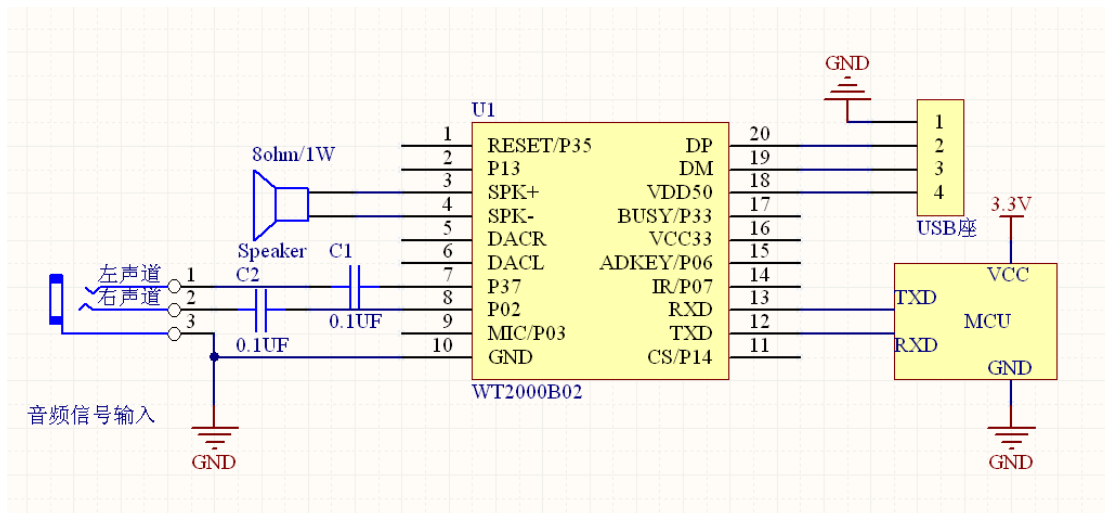

Note:

WT2000B02 is 3.3V IO system, direct connect with 3.3 V MCU. Connect with 5V MCU need to increase level to convert circuit

Single track record scene of external circuit input audio signal need use the apply circuit.

Suggest use external audio input signal within 2.8V.

Coupling capacity value is within 0.1uF to 1uF.

### Electric Parameter

Name	Function	Min Value	Typical Value	Max Value	Unit	Condition
VDD50	LDO input voltage	3.2	5.0	5.5	V	-
VDD33	LDO 3.3V output current	-	-	150	mA	Vout3.3>3.1V *note 1
SNR	Signal to Noise Ratio	-	92	-	dB	-
THD+N	Total Harmonic Distortion	-	-70	-	dB	No-load
PWRAB	DAC output power	-	-	16	mW	32 ohm Speaker
VPP	DAC max output amplitude voltage	-	-	2.8	V	-
Ps1	Standby power consumption (with TF card)	-	27.6	-	mA	Related with TF card consumption
Prec	Record Consumption (with TF card)	-	28.1	-	mA	Related with TF card consumption
P	Playing Consumption(no-load)	-	28.7	-	mA	Related with TF card consumption
VPPLINE	External audio input range	-	-	2.8	V	

## History Version

Version No.	Modified Date	Illustration
V1.0	27.02.14	Original Version